



QHC12MRE 12kW RF Heater Controller (Receiver) - 3 Phase Only

901350

Unit 9, Stort Valley Industrial Estate
Stansted Road, Bishop's Stortford
Hertfordshire, United Kingdom
CM23 2TU

Available at
www.shadowindustrial.co.uk
01279 466500
info@shadowindustrial.co.uk

Quick Start for QHC12MRE 12kW RF Heater Controller (receiver)

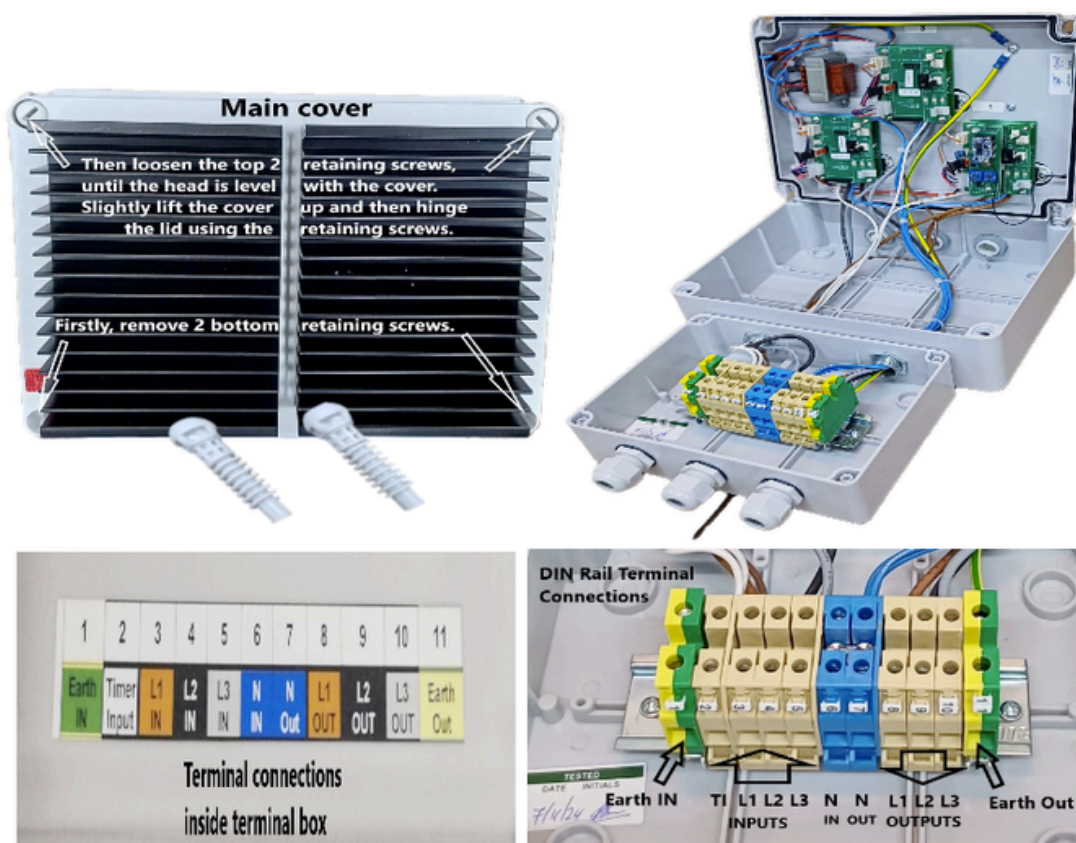
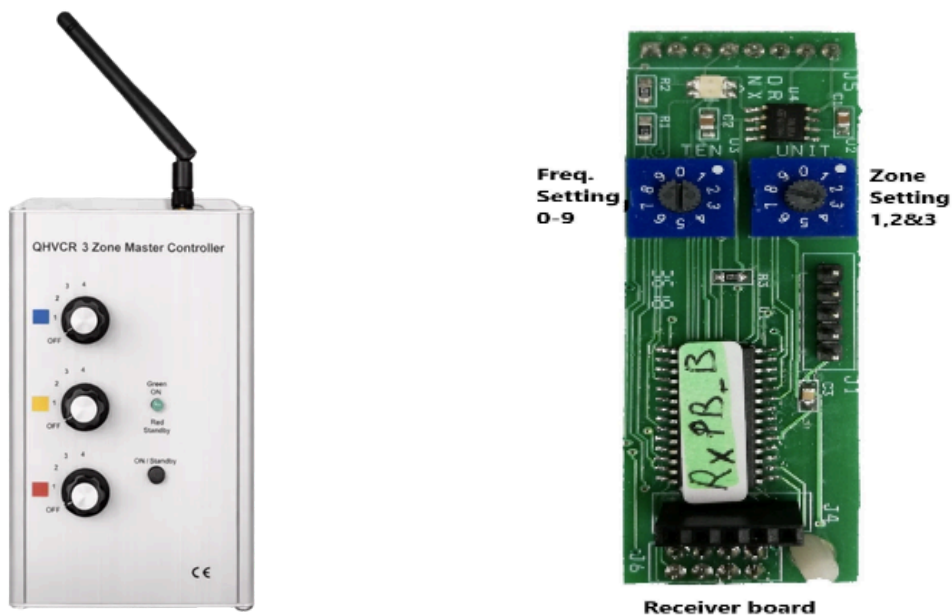

Fig 1

Fig 2

1. Remember isolate the Mains before removing the cover. Remove the cover by removing the 4 screws from the terminal box lid.
2. Use the three cable glands to bring the Mains cables into and out of the controller base .
3. Connect Mains IN - L1 brown to #3, L2 black to #4 and L3 grey to #5 wires to terminals marked L1 IN (3), L2 IN IN (4) and L3 IN (5). See Fig's 1 & 2. Then connect Neutral IN and Earth IN, N in blue to #6 and Earth in green/yellow to #1.
4. Connect the Infrared Heater to load outputs - L1 OUT from #8 brown , L2 OUT from #9 black, L3 OUT from #10 grey. The Neutral Out from #7 blue and the Earth OUT from #11 green/yellow. See Fig's 1 & 2
5. The trigger* from the 7-Day Programmable Timer is connected to Timer Input #2 white (2). Note: *a motion sensor (PIR) can be connected to this input instead of a Timer. See Fig's 1 & 2
6. When all connections are complete and connected correctly, check once again that the wiring is correct as per 3) & 4). Then replace the cover and tighten the fixing screws.
7. Turn ON or reconnect the Mains Power to the controller. The red neon lamp on the LHS will illuminate to indicate that the unit is LIVE.
8. The controller is now ready to be controlled by the wireless remote unit QHVCR. See instructions for QHVCR operation, page 2 follow steps 8) to 14).

QHVC 3 Zone RF Master Controller (transmitter)



9. There are three control dials Blue, Yellow & Red one for each zone. The QHC12MRE units are preset to operate in one of these zones. The QHC12MRE unit once preset will only operate in that designated zone. The factory setting is 1, this will be the Blue control dial.
10. Turn ON the QHVCR unit by pressing the ON/Standby button on the front panel. The Led indicator will flash orange – green – orange – green and remain Green to indicate that the unit is ready.
11. The QHC12MRE unit is preset as a Blue zone (1). Turn the Blue control dial to position 1. The heaters connected to the QHC12MRE units will come ON at the minimum setting 33%. Continue to turn the Blue control dial through position 2 to 4 until you reach the desired setting. Settings are OFF = 0%, 1 = 33%, 2 = 50%, 3 = 66% & 4 = 100%.
12. QHC12MRE units which are preset to Yellow & Red zones are controlled by the Yellow & Red control dials respectively and will operate as above in 10).
13. The QHVCR unit is powered by 3 x AAA battery's. So, the unit will automatically go into standby mode if the unit is inactive for more than 30 seconds. When the unit goes into standby mode all the QHC12MRE units will remain unchanged at the settings they were set at. The heaters will remain ON.
14. To change a setting just press the ON/Standby button and proceed as described in 9) & 10). However, while the QHVCR unit is ON, you can turn OFF all the heaters by pressing the ON/Standby button. This is indicated by the Led indicator flashing Red.
15. The previous settings will be remembered and will be restored when you press the ON/Stand by button again. Please note that the QHVCR remote Master Controller can control any number of QHC06MRE & QHC12MRE controllers as long as they are within range, up to 100 meters * (see specification sheet for the QHVCR unit)

Pairing (programming) Devices QHVCR & QHCxxMR

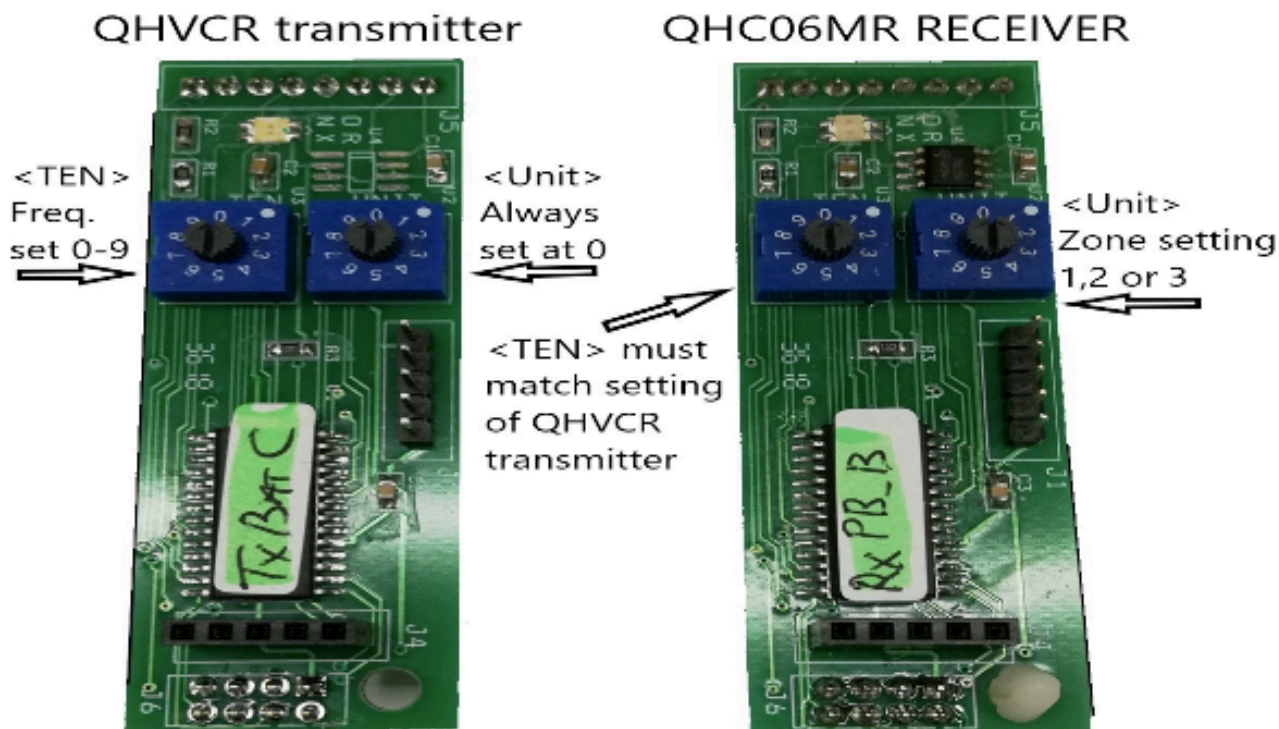

Pairing (programming) devices QHVCR (transmitter) and QHCxxMR (receivers).

1. The Left Hand Side rotary switches (TEN) on both boards must be set the same. The LHS switch (TEN) is used to set the RF frequency the setting must match on both boards. There are 10 possible frequencies that can be selected 0-9. If the settings on the LHS switch (TEN) do not match the devices will fail to operate.
2. Designating the transmitter and receiver. Both the left rotary switches are set at 0, this ensures that the transmitter marked 0 will communicate with the receiver marked 0. Setting the left rotary switch to 1, so the transmitter marked 1 will communicate with a receiver also marked 1. If the transmitter and receiver are not paired correctly they will not communicate and therefore will not operate; transmitter marked 0 will not communicate with a receiver marked 1. Remember a transmitter can be set at any number between 0-9 & the receiver must be matched correctly.
3. The Right Hand Side rotary switches (UNIT) are for setting the device to operate in a set zone. There are 3 possible zones that the controller can be set to. The RHS switch (UNIT) should be set to 1, 2 or 3.
 - Blue Zone 1 operation set RHS switch (UNIT) to 1
 - Yellow Zone 2 operation set RHS switch (UNIT) to 2
 - Red Zone 3 operation set RHS switch (UNIT) to 3

PIR motion detector (QHPIR) fitting



PIR motion detectors are passive infrared sensors an electronic device which is triggered by infrared light from the movement of objects in it's field of view. A PIR can be connected to a QHC12MRE controller.

This will enable the controller to turn ON the heaters only when the presence of a person or people are detected by the PIR.



The angle of the PIR and the viewing width of the lens will have to be adjusted to ensure the detection area is that which is required. Full lens width will have a large detection area. For a smaller area the lens narrow the lens using the lens mask.

Setting the Lens width correctly is crucial, if this is set incorrectly the PIR could be continuously be ON. This can cause the heaters to remain ON too.

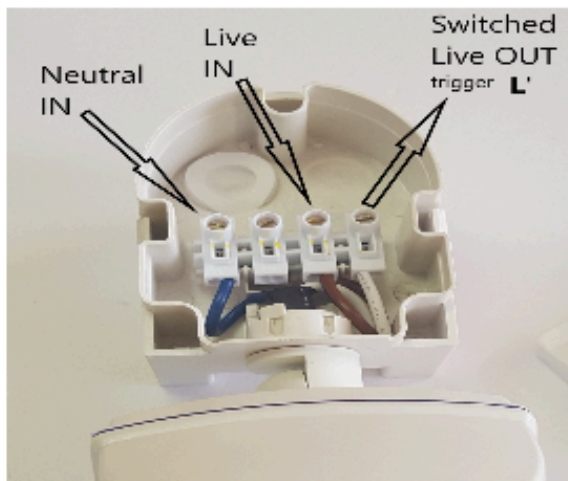

Connect the switched Live trigger L' to terminal #2 PIR Input on the QHC12MRE controller.

The switched Live OUT to the QHC12MRE controller is a Live 240V feed, this is only used as a signal Input to the controller.

7-Day programmable timer fitting option

A 7-Day programmable timer can be fitted as an option instead of the PIR. It is important note that only one or the other can be fitted to the QHC12MRE controller not both.

S1 & S2 are found on the printed circuit board (PCB) QHPCB-A, See fig 3

Default settings for S1 & S2

Remote OFF – S1 Jumper is factory set in the Off position pins 2 & 3,. For Manual operation.

PIR & 7-Day Timer OFF - S2 Slide switch is factory set in the Off position “ 2”. See Fig 3

To set up for a 7-Day programmable timer

S2 Slide switch must be set in the ON position “1”, See Fig 3

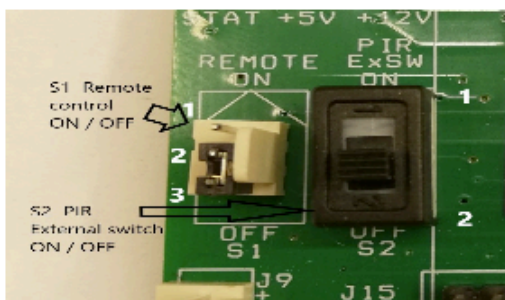
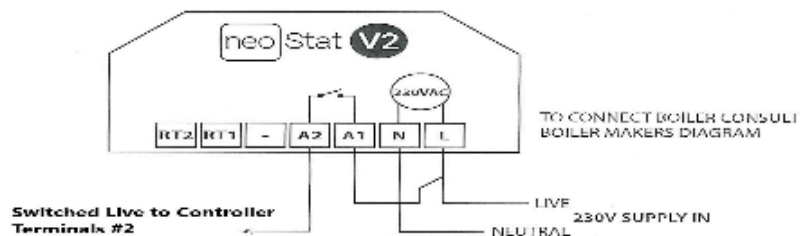

Fig 3 Slide switch S2 OFF position



Fig 4 Typical 7-Day Programmable Timer

Wiring Diagram - neoStat to QHC12MRE controller



This product must only be installed by a qualified electrician and comply with local installation regulations.

Fig 5 Wiring connection to the QHC12MRE controller

The switched Live trigger (L') through A2 terminal on the 7-Day timer is connected to terminal #2 on the DIN rail terminal block of the QHC12MRE controller See Fig 1,2 & 5. Once the 7-Day programmable timer is fitted correctly it will now control when the controller will be ON or OFF.

This function can be disabled by simply switching the S2 slide switch back to the OFF position 2

See Fig 3

Expandable heating system using a QHVCR & multiple QHC06MRE, QHC12MRE & QHC18MR controllers.

Using the remote 3 zone QHVCR controller the area being heated can be zoned into three areas Blue, Yellow & Red. Each zone can be controlled separately, this includes setting each zone at a different level.

There are 5 power level settings > Off – 1 (33%) - 2 (50%) - 3 (66%) - 4 (100%). Any combination of our QHC controllers can be used in the proposed zoned layout below. There are 6kW QHC06MR, 12kW QHC12MRE & 18kW QHC18MR controllers available to be used depending on the over all number of heaters required.

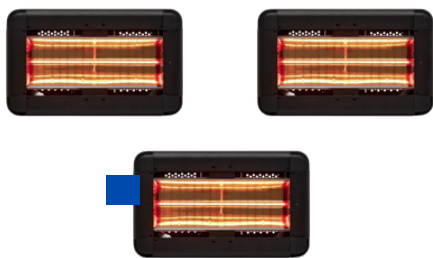

 Blue zone 6kW controller set a (0) >0-1



Blue zone has 3 x 2kW heaters - total 6kW

 Yellow zone 12kW controller set a (0) >0-2

Yellow zone has 1 x 9kW heater - total 9kW

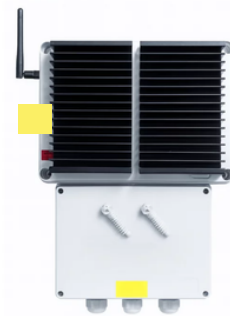
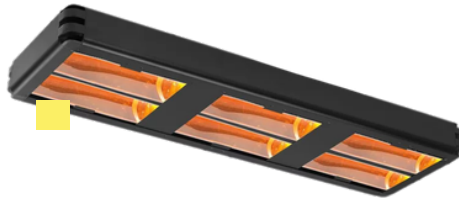

 Red zone 18kW controller set as (0) > 0-3

Red zone has 1 x 12kW heater - total 12kW

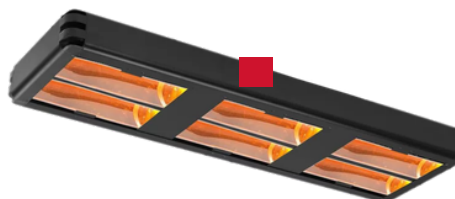

Remote 3 zone QHVCR controller set as an (0) > 0

This configuration allows the heaters in the blue zone to be controlled by the 1st dial on the remote control, setting levels at off to 4. the yellow zone is controlled by the 2nd dial and the red zone is controlled by the 3rd dial.



For larger installations multiple controllers and heaters can be added to each zone where required

It is recommended that each heater should be fused with a spur. Each controller should have: **Type C MCB circuit breaker and the whole installation must have an Isolation switch**

Wiring diagram for 3 phase 12kW QHC12MRE controller.

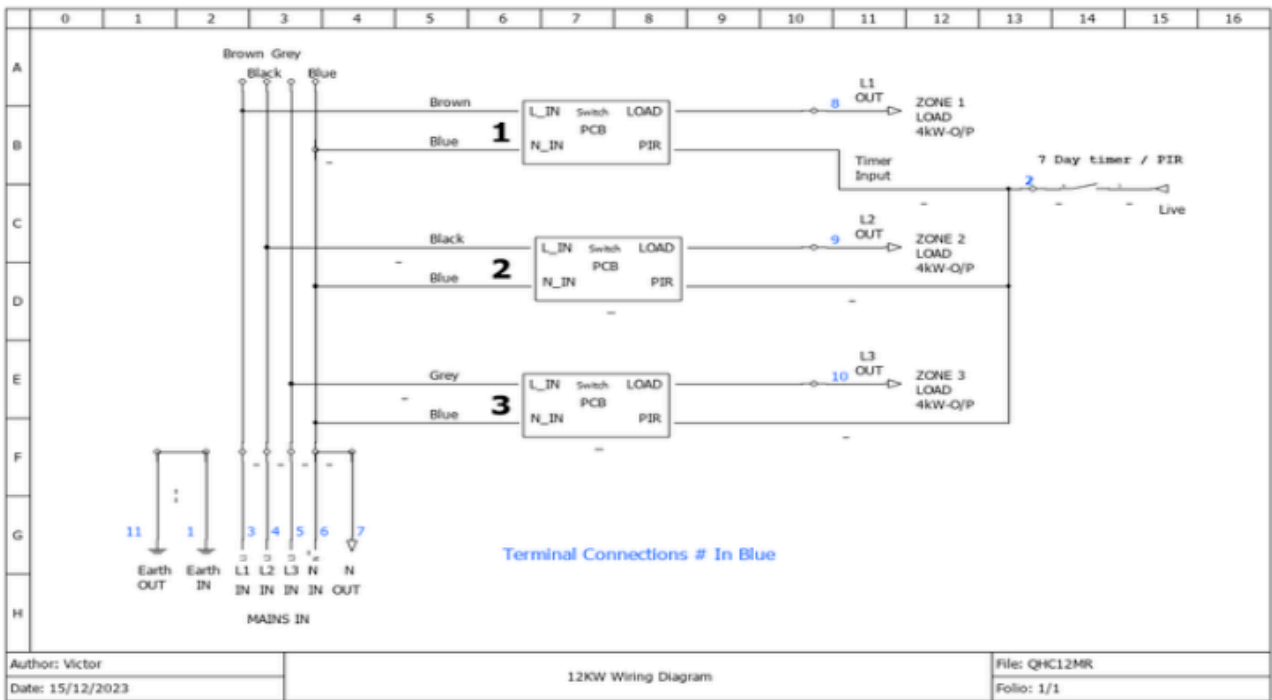

Wiring diagram for 3 phase 18kW & 24kW controllers.

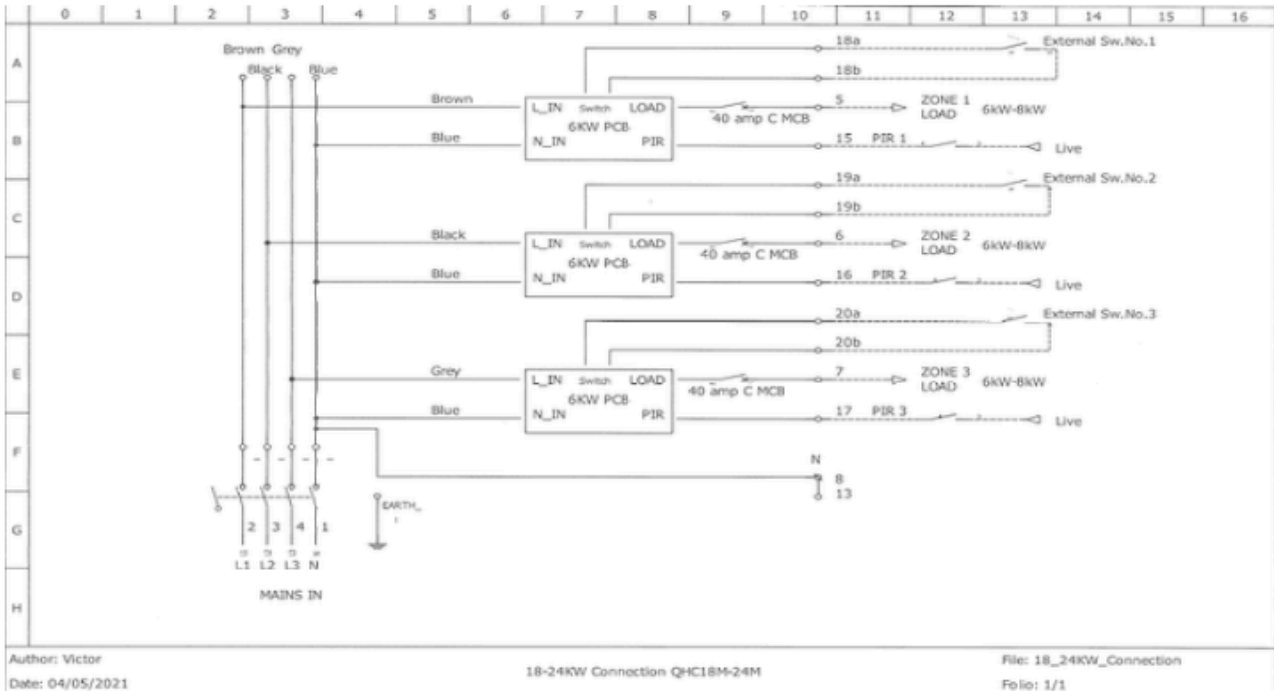

Remember to fit C-curve MCB circuit breakers.
 Also note, single module RCBO devices should not be connected.

Flickering - J17 Red jumper link



Fig 6 QHPCB-A

If the user experiences flickering of lights after the system is installed.

The cause is as follows,

- The power control is accomplished by omitting half mains cycles, this is done to ensure no electromagnetic interference.
- On occasions when a half cycle is switched off it can cause a small voltage change on the mains wires which can be seen on some types of lights.

The solution is as follows below

You can move the Red jumper link to positions 2&3 on the header marked J17 on all 3 printed circuit boards QHPCB-A, see fig 6. This limits control levels to 50% & 100% which cannot be seen on any type of light.

The default setting for the Controller is with the Red jumper link in positions 1&2 and should be left in this location for normal operation.

When J17 is set in the default position all four power levels will function as normal. However, when set in positions 2&3 only power levels 2 & 4 will function.

Trouble Shooting

The QHC12MRE (receiver) is not working.

- Check that the unit is wired correctly and follow the installation procedure on page 1. The neon indicator should be ON to indicate the the Mains is connected correctly. Then check that the status LED D5, the +5v LED D6 & the +12v LED D7 are all ON green. If the status LED is Red, this indicates that there is a problem with the mains connection to the board.
- If the +5v or +12v LEDs are Red this indicates that there is a problem with the processor chip or a power supply problem.

There is no communication between the QHC12MRE & QHVCR

- The units may not be paired correctly. First determine what frequency the QHVCR is set at. The setting is marked at the back of the unit. If it's marked (0) you must check to see if the QHC12MRE is also set the same and is also marked (0). If they are different then the controller QHC12MRE will not work.
- If needed you can reset the controller QHC12MRE by following the Pairing instructions on page 3.

Paired transmitter QHVCR & receiver QHC12MRE still won't communicate even when they are both set the same.

- The small antenna RF PCB could be the problem. Check if the small LED flashes Red when the transmitter QHVCR is turn ON & OFF. The communication is good between the two units when the LED flashes Red. Otherwise if the LED remains ON Green then the RF PCB is faulty and needs to be replaced.
- However, if the RF PCB is working and the LED flashes Red but the controller QHC12MRE is still not working. The cable connection between the RF PCB and the Antenna could be faulty and may need to be replaced.

Yellow zone is not working !

- The problem could be the receiver is set as a blue zone or red zone. If this is the case all you have to do is re-set the right hand rotary switch to position 2. See page 3

Circuit Breaker MCB keeps tripping when the heaters are turned ON !

- Ensure that the MCB is a Type C where there are likely to be surges. A common fault is to use Type B but these will always fail. Replace with Type C and the problem should be fixed.

If the controller does not respond to power level settings 3 & 4.

- Check for a loose or missing Black connector ref. J8 (TMP2) header on the printed circuit board (PCB).

Expandable heating system using a QHVCR & multiple QHC06MRE, QHC12MRE & QHC18MR controllers.

Using the remote 3 zone QHVCR controller the area being heated can be zoned into three area's Blue, Yellow & Red. Each zone can be controlled separately, this includes setting each zone at a different level.

There are 5 power level settings > Off – 1 (33%) - 2 (50%) - 3 (66%) - 4 (100%).

Any combination of our QHC controllers can be used in the proposed zoned layout below. There are 6kW QHC06MR, 12kW QHC12MRE & 18kW QHC18MR controllers available to be used depending on the over all number of heaters required.



Blue zone has 3 x 2kW heaters - total 6kW

Yellow zone 12kW controller set a (0) >0-2



Yellow zone has x 4.5kW - total 9kW

Red zone 18kW controller set as (0) >0-3

Red zone has 1 x 12kW heater- total 12kW

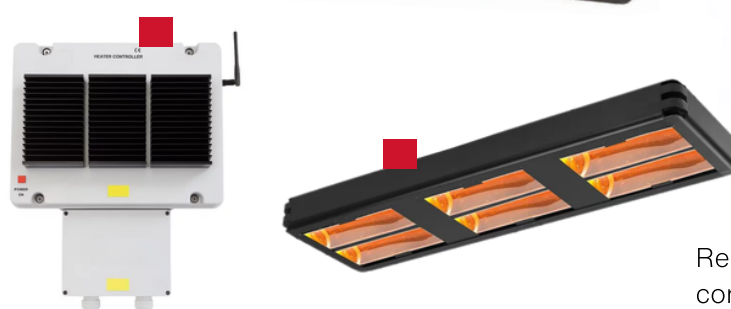

Remote 3 zone QHVCR controller set as an (0) > 0

This configuration allows the heaters in the blue zone to be controlled by the 2nd dial on the heater control, setting levels off to 4. The yellow zone is controlled by the 2nd dial and the red zone is controlled by the 3rd dial.

For larger installations multiple controllers and heaters can be added to each zone where required

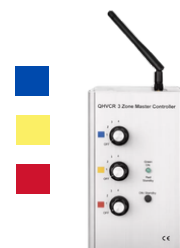

It is recommended that each heater should be fused with a spur. Each controller should have a **C-curve MCB circuit breaker and the whole installation must have an Isolation switch.**

Supply Voltage: 3 phase 415V AC 50Hz

Max. Load Capacity: 12kW

Input	Earth in (Grn/Yel)	terminal 1
	L1 (Brown)	terminal 3
	L2 (Black)	terminal 4
	L3 (Grey)	terminal 5
	Neutral in (Blue)	terminal 6
Aux Input	Timer or PIR input trigger (white)	terminal 2
Output	Neutral Out (Blue)	terminal 7
	Switched L1 out (Brown)	terminal 8
	Switched L2 out (Black)	terminal 9
	Switched L3 out (Grey)	terminal 10
	Earth out (Grn/Yel)	terminal 11

Transmission: RF 433MHz

**Range: Antenna Standard - Up to 100 meters (line of sight)
Antenna Extended - Up to 200 meters (line of sight)**

IP Rating: IP56

Dimensions: 380mm x 260mm 140mm

Weight 3.5Kgs

Notes: C-curve MCB circuit breakers must be used when installing this product. It is not recommended that heaters connected to this controller should be fused individually with a spur